

RC4190

Micropower Switching Regulator

Features

- High efficiency – 85% typical
- Low quiescent current – 215 μ A
- Adjustable output – 1.3V to 30V
- High switch current – 200 mA
- Bandgap reference – 1.31V
- Accurate oscillator frequency – $\pm 10\%$
- Remote shutdown capability
- Low battery detection circuitry
- Low component count
- 8-lead packages including small outline (SO-8)

Description

The RC4190 monolithic IC is a low power switch mode regulator intended for miniature power supply applications. This DC-to-DC converter IC provides all of the active components needed to create supplies for micropower circuits (load power up to 400 mW, or up to 10W with an external power transistor). Contained internally are an oscillator, switch, reference, comparator, and logic, plus a discharged battery detection circuit.

Application areas include on-card circuits where a non-standard voltage supply is needed, or in battery operated instruments where an RC4190 can be used to extend battery lifetime.

These regulators can achieve up to 85% efficiency in most applications while operating over a wide supply voltage range, 2.2V to 30V, at a very low quiescent current drain of 215 μ A.

The standard application circuit requires just seven external components for step-up operation: an inductor, a steering diode, three resistors, a low value timing capacitor, and an electrolytic filter capacitor. The combination of simple application circuit, low supply current, and small package make the RC4190 adaptable to a wide range of miniature power supply applications.

The RC4190 is most suited for single ended step-up ($V_{OUT} > V_{IN}$) circuits because the NPN internal switch transistor is referenced to ground. It is complemented by another Raytheon micropower switching regulator, the RC4391, which is dedicated to step-down ($V_{OUT} < V_{IN}$) and inverting ($V_{OUT} = -V_{IN}$) applications. Between the two devices the ability to create all three basic switching regulator configurations is assured. Refer to the RC4391 data sheet for step-down and inverting applications.

Block Diagram

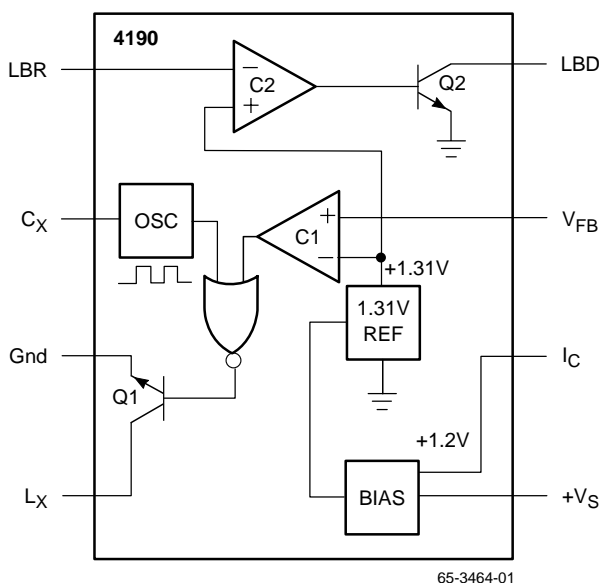

With some optional external components the application circuit can be designed to signal a display when the battery has decayed below a predetermined level, or designed to signal a display at one level and then shut itself off after the battery decays to a second level. See the applications section for these and other unique circuits.

The RC4190 micropower switching regulator series consists of three devices, each with slightly different specifications. The RM4190 has a 1.5% maximum output voltage tolerance, 0.2% maximum line regulation, and operation to 30V. The RC4190 has a 5.0% maximum output voltage tolerance, 0.5% maximum line regulation, and operation to 24V. Other specifications are identical. Each type is available in plastic and ceramic DIPs, or SO-8 packages.

Pin Assignments

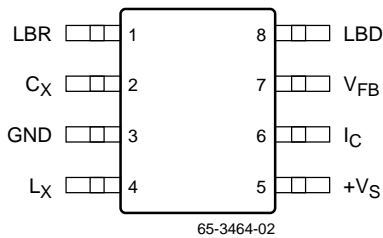

Pin Definitions

Pin Name	Pin Number	Pin Function Description
LBR	1	Low Battery (Set) Resistor
CX	2	Timing Capacitor
Gnd	3	Ground
LX	4	External Inductor
+VS	5	Positive Supply Voltage
IC	6	Reference Set Current
VFB	7	Feedback Voltage
LBD	8	Low Battery Detector Output

Absolute Maximum Ratings

(beyond which the device may be damaged)¹

Parameter		Min	Typ	Max	Units
Supply Voltage (Without External Transistor)	RM4190			30	V
	RC4190			24	V
P _{DTA} < 50°C	SOIC			300	mW
	PDIP			468	mW
	CerDIP			833	mW
Operating Temperature	RM4190	-55		125	°C
	RC4190	0		70	°C
Storage Temperature		-65		150	°C
Junction Temperature	SOIC, PDIP		125		°C
	CerDIP		175		°C
Switch Current	Peak			375	mA
For T _A > 50°C Derate at	SOIC		4.17		mW/°C
	PDIP		6.25		mW/°C
	CerDIP		8.33		mW/°C

Note:

1. Functional operation under any of these conditions is NOT implied.

Operating Conditions

Parameter			Min	Typ	Max	Units
θ _{JC}	Thermal resistance	CerDIP		45		°C/W
θ _{JA}	Thermal resistance	SOIC		200		°C/W
		PDIP		160		°C/W
		CerDIP		120		°C/W

Electrical Characteristics

(+V_S = +6.0V, I_C = 5.0 μA over the full operating temperature range unless otherwise noted.)

Symbol	Parameters	Conditions	RM4190			RC4190			Units
			Min	Typ	Max	Min	Typ	Max	
+V _S	Supply Voltage		2.6		30	2.6		24	V
V _{REF}	Reference Voltage (Internal)		1.25	1.31	1.37	1.20	1.31	1.42	V
I _{SY}	Supply Current	Measure at Pin 5 I ₄ = 0		235	350		235	350	μA
	Line Regulation	0.5 V _{OUT} < V _S < V _{OUT}		0.2	0.5		0.5	1.0	% V _O
I _L	Load Regulation	V _S = 0.5 V _{OUT} P _L = 150 mW		0.5	1.0		0.5	1.0	% V _O
I _C	Reference Set Current		1.0	5.0	50	1.0	5.0	50	μA
I _{CO}	Switch Leakage Current	V ₄ = 24V (RC4190) 30V (RM4190)			30			30	μA
I _{SO}	Supply Current (Disabled)	V _C ≤ 200 mV			30			30	μA
I _{LBD}	Low Battery Output Current	V ₈ = 0.4V, V ₁ = 1.1V	500	1200		500	1200		μA
	Oscillator Frequency Temperature Drift			±200			±200		ppm/°C

Electrical Characteristics

(+V_S = +6.0V, I_C = 5.0 μA, and T_A = +25°C unless otherwise noted.)

Symbol	Parameters	Conditions	RM4190			RC4190			Units
			Min	Typ	Max	Min	Typ	Max	
+V _S	Supply Voltage		2.2		30	2.2		24	V
V _{REF}	Reference Voltage (Internal)		1.29	1.31	1.33	1.24	1.31	1.38	V
I _{SW}	Switch Current	V ₄ = 400 mV	100	200		100	200		mA
I _{SY}	Supply Current	Measure at Pin 5 I ₄ = 0		215	300		215	300	μA
ef	Efficiency			85			85		%
	Line Regulation	0.5 V _{OUT} < V _S < V _{OUT}		0.04	0.2		0.04	0.5	% V _O
I _L	Load Regulation	V _S = +0.5 V _{OUT} P _L = 150 mW		0.2	0.5		0.2	0.5	% V _O
F _O	Operating Frequency Range		0.1	25	75	0.1	25	75	kHz
I _C	Reference Set Current		1.0	5.0	50	1.0	5.0	50	μA
I _{CO}	Switch Leakage Current	V ₄ = 24V (RC4190) 30V (RM4190, RC4190A)		0.01	5.0		0.01	5.0	μA
I _{SO}	Supply Current (Disabled)	V _C ≤ 200 mV		0.1	5.0		0.1	5.0	μA
I ₁	Low Battery Bias Current	V ₁ = 1.2V		0.7			0.7		μA
I _{CX}	Capacitor Charging Current			8.6			8.6		μA
	Oscillator Frequency Tolerance			±10			±10		%
+V _{THX}	Capacitor Threshold Voltage +			1.4			1.4		V
-V _{THX}	Capacitor Threshold Voltage –			0.5			0.5		V
I _{FB}	Feedback Input Current	V ₇ = 1.3V		0.1			0.1		μA
I _{LBD}	Low Battery Output Current	V ₈ = 0.4V, V ₁ = 1.1V	500	1500		500	1500		μA

Typical Performance Characteristics

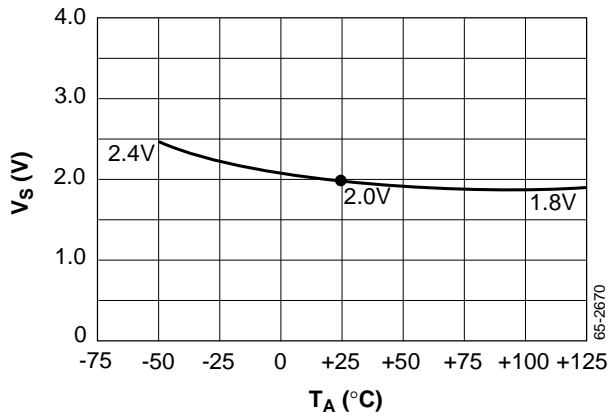

Figure 1. Minimum Supply Voltage vs. Temperature

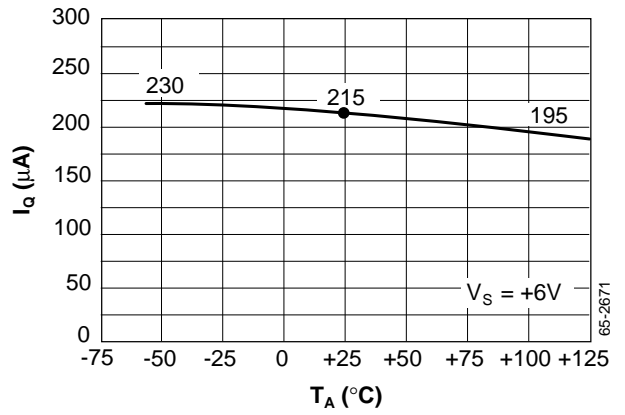

Figure 2. Quiescent Current vs. Temperature

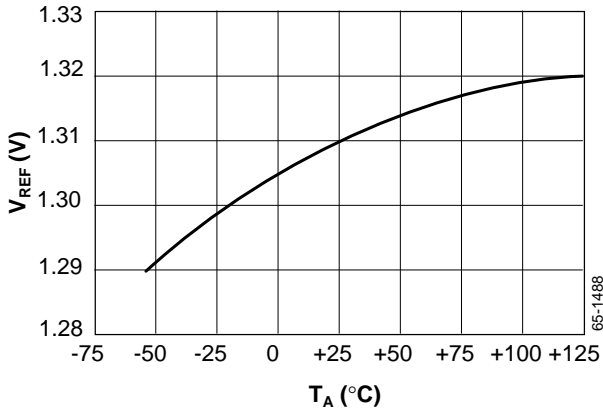

Figure 3. Reference Voltage vs. Temperature

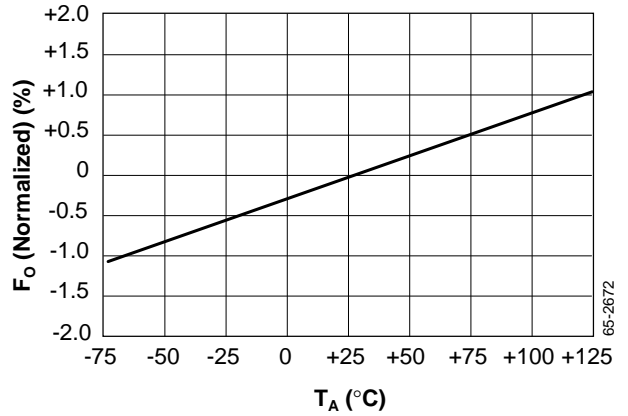

Figure 4. Oscillator Frequency vs. Temperature

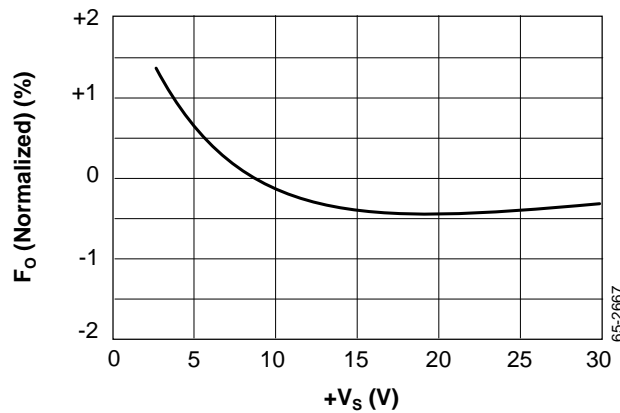

Figure 5. Minimum Supply Voltage vs. Temperature

Principles of Operation

Simple Step-Up Converter

The most common application, the step-up regulator, is derived from a simple step-up ($V_{OUT} > V_{BAT}$) DC-to-EC Converter (Figure 6).

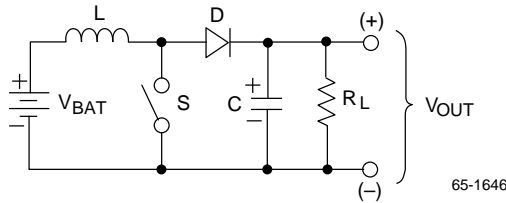

Figure 6. Simple Set-Up

When switch S is closed, the battery voltage is applied across the inductor L. Charging current flows through the inductor, building up a magnetic field, increasing as the switch is held closed. While the switch is closed, the diode D is reverse biased (open circuit) and current is supplied to the load by the capacitor C. Until the switch is opened, the inductor current will increase linearly to a maximum value determined by the battery voltage, inductor value, and the amount of time the switch is held closed ($I_{MAX} = V_{BAT} / L \times T_{ON}$). When the switch is opened, the magnetic field collapses, and the energy stored in the magnetic field is converted into a discharge current which flows through the inductor in the same direction as the charging current. Because there is no path for current to flow through the switch, the current must flow through the diode to supply the load and charge the output capacitor.

If the switch is opened and closed repeatedly, at a rate much greater than the time constant of the output RC, then a constant dc voltage will be produced at the output.

An output voltage higher than the input voltage is possible because of the high voltage produced by a rapid change of current in the inductor. When the switch is opened, the inductor voltage will instantly rise high enough to forward bias the diode, to $V_{OUT} + V_D$.

In the complete RC4190 regulator, a feedback control system adjusts the on time of the switch, controlling the level of inductor current, so that the average inductor discharge current equals the load current, thus regulating the output voltage.

Complete Step-Up Regulator

A complete schematic of the minimum step-up application is shown in Figure 7. The ideal switch in the DC-to-DC Converter diagram is replaced by an open collector NPN transistor Q1. C_F functions as the output filter capacitor, and D1 and L_X replace D and L.

When power is first applied, the current in R1 supplies bias current to pin 6 (I_C). This current is stabilized by a unity gain current source amplifier and then used as bias current for the 1.31V bandgap reference. A very stable bias current generated by the bandgap is mirrored and used to bias the remainder of the chip. At the same time the RC4190 is starting up, current will flow through the inductor and the diode to charge the output capacitor to $V_{BAT} - V_D$.

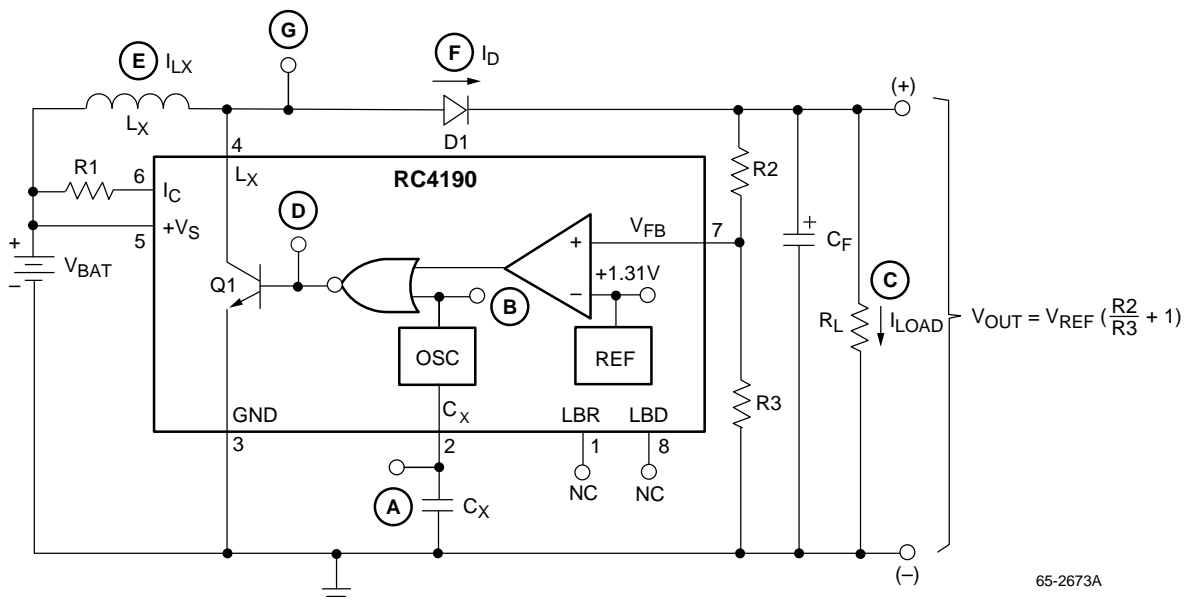
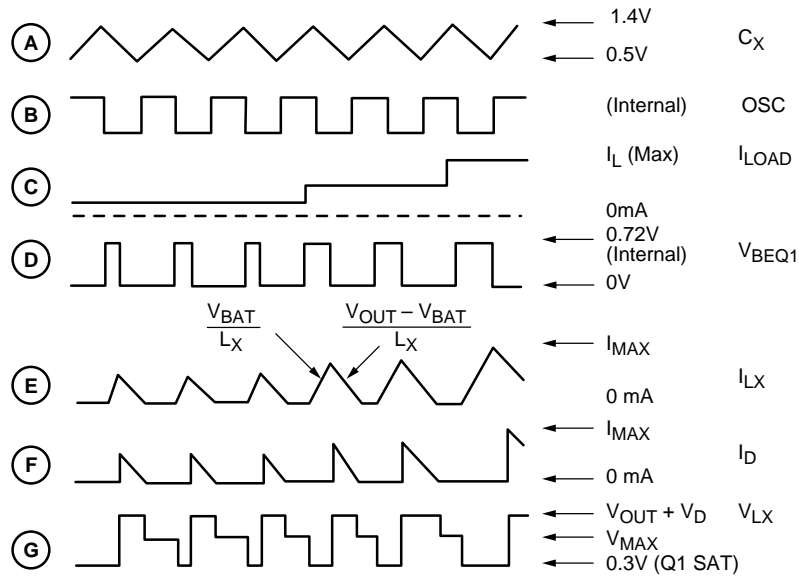

Figure 7. Complete Step-Up Regulator



65-2674

Figure 8. Step-Up Regulator Waveforms

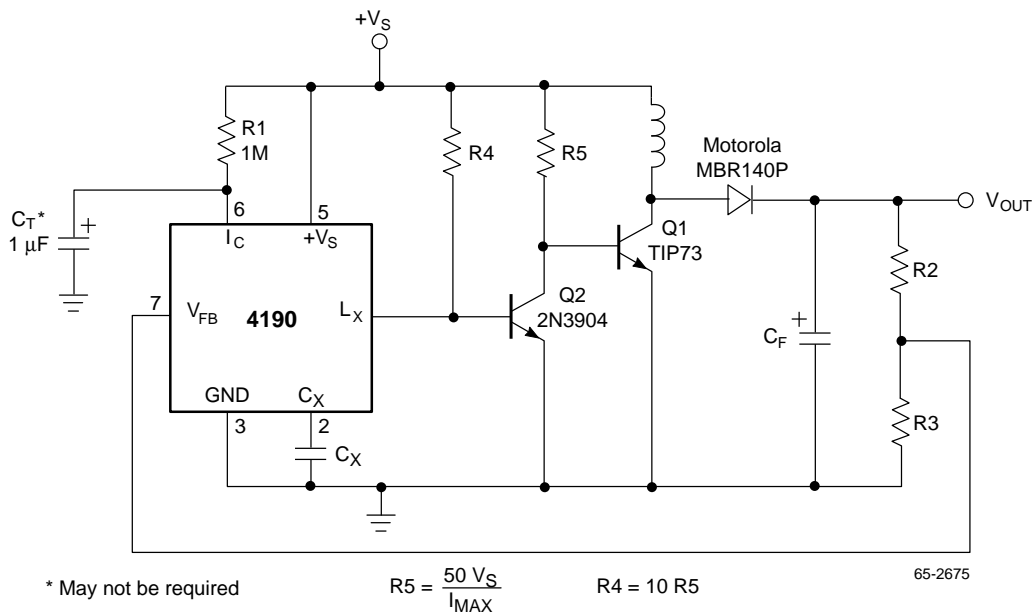

Figure 9. High Power Step-Up Regulator

(With the addition of a power transistor (TIP73) and a few components, the 4190 can accommodate load power up to 10W.)

At this point, the feedback (pin 7) senses that the output voltage is too low, by comparing a division of the output voltage (set by the ratio of R2 to R3) to the +1.31V reference. If the output voltage is too low then the comparator output changes to a logical zero. The NOR gate then effectively ANDs the oscillator square wave with the comparator signal; if the comparator output is zero AND the oscillator output is low, then the NOR gate output is high and the switch transistor will be forced on. When the oscillator goes high again, the NOR gate output goes low and the switch transistor will turn off. This turning on and off of the switch transistor performs

the same function that opening and closing the switch in the simple DC-to-DC Converter does; i.e., it stores energy in the inductor during the on time and releases it into the capacitor during the off time.

The comparator will continue to allow the oscillator to turn the switch on and off until enough charge has been delivered to the capacitor to raise the feedback voltage above 1.31V.

Thereafter, this feedback system will vary the duration of the on time in response to changes in load current or battery

voltage (see Figure 8). If the load current increases (waveform C), then the transistor will remain on (waveform D) for a longer portion of the oscillator cycle (waveform B), thus allowing the inductor current (waveform E) to build up to a higher peak value. The duty cycle of the switch transistor varies in response to changes in load and time.

The inductor value and oscillator frequency must be carefully tailored to the battery voltage, output current, and ripple requirements of the application (refer to the Design Equations Section). If the inductor value is too high or the oscillator frequency is too high, then the inductor current will never reach a value high enough to meet the load current drain and the output voltage will collapse. If the inductor value is too low or the oscillator frequency too low, then the inductor current will build up too high, causing excessive output voltage ripple, or over stressing of the switch transistor, or possibly saturating the inductor.

Simple Step-Down Converter

Figure 10 shows a step-down DC-to-DC Converter ($V_{OUT} \leq V_{BAT}$) with no feedback control.

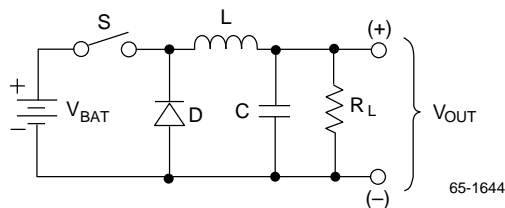

Figure 10. Simple Step-Down Converter

When S is closed, the battery voltage minus the output voltage is applied across the inductor. All of the inductor current will flow into the load until the inductor current exceeds the load current. The excess current will then charge the capacitor and the output voltage will rise. When S is opened, the

voltage applied across the inductor will discharge into the load. As in the step-up case, the average inductor current equals the load current. The maximum inductor current I_{MAX} will equal $(V_{BAT} - V_{OUT})/L$ times the maximum on time of the switch transistor (T_{ON}). Current flows to the load during both half cycles of the oscillator.

Complete Step-Down Regulator

Most step-down applications are better served by the RC4391 step-down and inverting switching regulator (refer to the RC4391 data sheet). However, there is a range of load power for which the RC4190 has an advantage over the RC4391 in step-down applications. From approximately 500 mW to 2W of load power, the RC4190 step-down circuit of Figure 6 offers a lower component count and simpler circuit than the comparable RC4391 circuit, particularly when stepping down a voltage greater than 30V.

Since the switch transistor in the RC4190 is in parallel with the load, a method must be used to convert it to a series connection for step-down applications. The circuit of Figure 11 accomplishes this. The 2N2907 replaces S of Figure 10, and R6 and R7 are added to provide the base drive to the 2N2907 in the correct polarity to operate the circuit properly.

Greater Than 30V Step-Down Regulator

Adding a zener diode in series with the base of the 2N2907 allows the battery voltage to increase by the value of the zener, with only a slight decrease in efficiency. As an example, if a 24V zener is used, the maximum battery voltage can go to $48V^2$ when using a RC4190. Refer to Figure 12.

Notes:

1. The addition of the zener diode will not alter the maximum change of supply. With a 24V zener, the circuit will stop operating when the battery voltage drops below $24V + 2.2V = 26.2V$.
2. Maximum battery voltage is 54V when using RM4190 ($30V + 24V$).

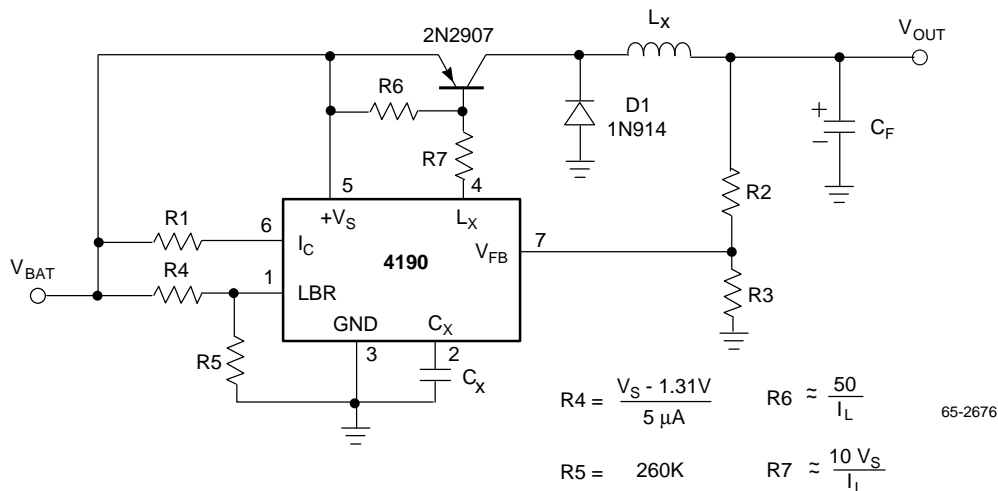

Figure 11. Complete Step-Down Regulator

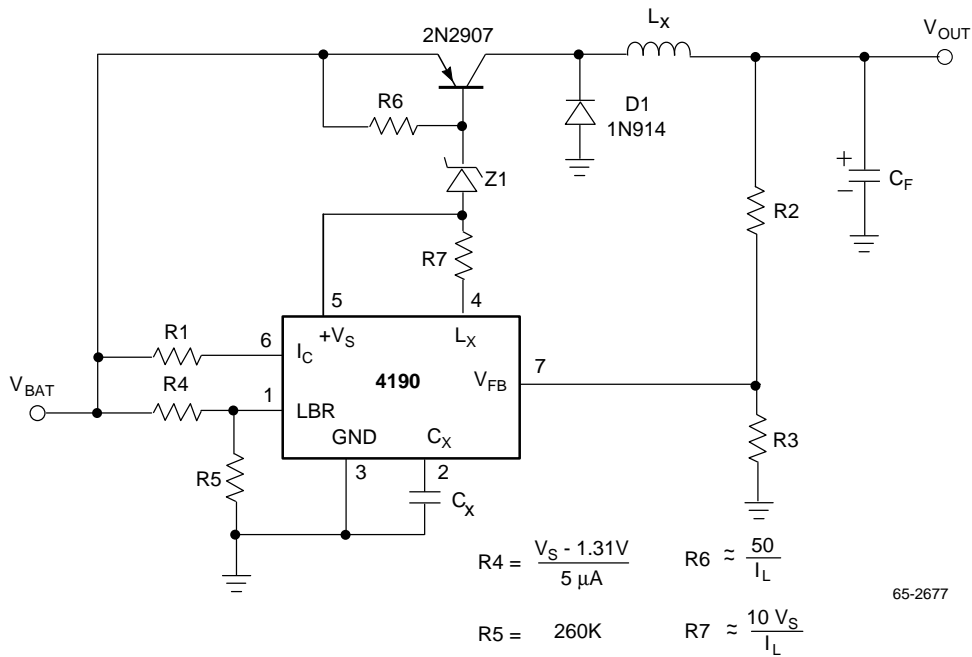

Figure 12. Step-Down Regulator Greater Than 30V

Design Equations

The inductor value and timing capacitor (C_X) value must be carefully tailored to the input voltage, input voltage range, output voltage, and load current requirements of the application. The key to the problem is to select the correct inductor value for a given oscillator frequency, such that the inductor current rises to a high enough peak value (I_{MAX}) to meet the average load current drain. The selection of this inductor value must take into account the variation of oscillator frequency from unit to unit and the drift of frequency over temperature. Use $\pm 20\%$ as a maximum change from the nominal oscillator frequency.

The worst-case conditions for calculating ability to supply load current are found at the minimum supply voltage; use $+V_S$ (min) to calculate the inductor value. Worst-case conditions for ripple are at $+V_S$ (max).

The value of the timing capacitor is set according to the following equation:

$$f_O \text{ (Hz)} = \frac{2.4 \times 10^6}{C_X \text{ (pF)}}$$

The squarewave output of the oscillator is internal and cannot be directly measured, but is equal in frequency to the triangle waveform measurable at pin 4. The switch transistor is normally on when the triangle waveform is ramping up and off when ramping down. Capacitor selection depends on the application; higher operating frequencies will reduce the output voltage ripple and will allow the use of an inductor with a physically smaller inductor core, but excessively high frequencies will reduce load driving capability and efficiency.

Find a value for the start-up resistor R1:

$$R1 = \frac{V_S - 1.2V}{5\mu A}$$

Find a value for the feedback resistors R2 and R3:

$$R2 = \frac{V_{OUT} - 1.31V}{I_A}$$

$$R3 = \frac{1.31V}{I_A}$$

Where I_A is the feedback divider current (recommended value is between $50\mu A$ and $100\mu A$).

Step-Up Design Procedure

1. Select an operating frequency and timing capacitor as shown above (10 kHz to 40 kHz is typical).
2. Find the maximum on time (add $5\mu s$ for the turn-off base recombination delay of Q1):

$$T_{ON} = \frac{1}{2f_O} + 5\mu s$$

3. Calculate the peak inductor current I_{MAX} (if this value is greater than 375 mA , then an external power transistor must be used in place of Q1):

$$I_{MAX} = \left(\frac{V_{OUT} + V_D - V_S}{(f_O) T_{ON} [V_S - V_{SW}]} \right) 2I_L$$

where: V_S = supply voltage

V_D = diode forward voltage

I_L = dc load current

V_{SW} = saturation voltage of Q1 (typ $0.5V$)

- Find an inductance value for L_X :

$$L_X \text{ (Henries)} = \left(\frac{V_S - V_{SW}}{I_{MAX}} \right) T_{ON}$$

- The inductor chosen must exhibit approximately this value at a current level equal to I_{MAX} .
- Calculate a value for the output filter capacitor:

$$C_F \text{ (}\mu\text{F)} = \frac{T_{ON} \left(\frac{V_S I_{MAX}}{V_{OUT}} + I_L \right)}{V_R}$$

where V_R = ripple voltage (peak)

Step-Down Design Procedure

- Select an operating frequency.
- Determine the maximum on time (T_{ON}) as in the step-up design procedure.
- Calculate I_{MAX} :

$$I_{MAX} = \frac{2I_L}{(F_O) (T_{ON}) \left(\frac{V_S - V_{OUT}}{V_{OUT} - V_D} \right) + 1}$$

- Calculate L_X :

$$L_X = \left(\frac{V_S - V_{OUT}}{I_{MAX}} \right) (T_{ON})$$

- Calculate a value for the output filter capacitor:

$$C_F \text{ (}\mu\text{F)} = \frac{T_{ON} \left(\frac{(V_S - V_{OUT}) I_{MAX}}{V_{OUT}} + I_L \right)}{V_R}$$

Alternate Design Procedure

The design equations above will not work for the certain input/output voltage ratios, and for these circuits another method of defining component values must be used. If the slope of the current discharge waveform is much less than the slope of the current charging waveform, then the inductor current will become continuous (never discharging completely), and the equations will become extremely complex. So, if the voltage applied across the inductor during the charge time is greater than during the discharge time, used the design procedure below. For example, a step-down circuit with 20V input and 5V output will have approximately 15V across the inductor when charging, and approximately 5V when discharging. So in this example, the inductor current will be continuous and the alternate procedure will be necessary.

- Select an operating frequency (a value between 10 kHz and 40 kHz is typical).

- Build the circuit and apply the worst case conditions to it, i.e., the lowest battery voltage and the highest load current at the desired output voltage.
- Adjust the inductor value down until the desired output voltage is achieved, then go a little lower (approximately 20%) to cover manufacturing tolerances.
- Check the output voltage with an oscilloscope for ripple, at high supply voltages, at voltages as high as are expected. Also check for efficiency by monitoring supply and output voltages and currents [eff = (VOUT)(IOUT)/(+VS)(ISY) x 100%].
- If the efficiency is poor, go back to (1) and start over. If the ripple is excessive, then increase the output filter capacitor value or start over.

Compensation

When large values (>50 kΩ) are used for the voltage setting resistors, R2 and R3 of Figure 7, stray capacitance at the VFB input can add a lag to the feedback response, destabilizing the regulator, increasing low frequency ripple, and lowering efficiency. This can often be avoided by minimizing the stray capacitance at the VFB node. It can also be remedied by adding a lead compensation capacitor of 100 pF to 10 nF in parallel with R2 in Figure 7.

Inductors

Efficiency and load regulation will improve if a quality high Q inductor is used. A ferrite pot core is recommended; the wind-yourself type with an air gap adjustable by washers or spacers is very useful for breadboarding prototypes. Care must be taken to choose a permeable enough core to handle the magnetic flux produced at I_{MAX} ; if the core saturates, then efficiency and output current capability are severely degraded and excessive current will flow though the switch transistor. A pot core inductor design section is provided later in this datasheet.

An isolated AC current probe for an oscilloscope (example: Tektronix P6042) is an excellent tool for saturation problems; with it the inductor current can be monitored for non-linearity at the peaks (a sign of saturation).

Low Battery Detector

An open collector signal transistor Q2 with comparator C2 provides the designer with a method of signaling a display or computer whenever the battery voltage falls below a programmed level (see Figure 8). This level is determined by the +1.3V reference level and by the selection of two external resistors according to the equation:

$$V_{TH} = V_{REF} \left(\frac{R_4}{R_5} + 1 \right)$$

Where V_{TH} = Threshold Voltage for Detection

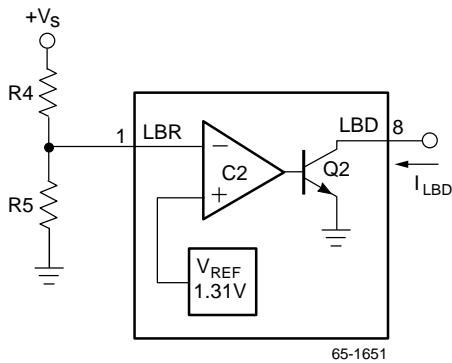

Figure 13. Low Battery Detector

When the battery voltage drops below this threshold Q2 will turn on and sink over 1500 μA typically. The low battery detector circuitry may also be used for other, less conventional applications (see Figures 19 and 20).

Automatic Shutdown

The bias control current for the reference is externally set by a resistor from the IC pin to the battery. This current can vary from 1.0 μA to 50 μA without affecting the operation of the IC. Interrupting this current will disable the entire circuit, causing the output voltage to go to 0V for step-down applications, and reducing the supply current to less than 1.0 μA .

Automatic shutdown of the RC4190 can be achieved using the circuit of Figure 14.

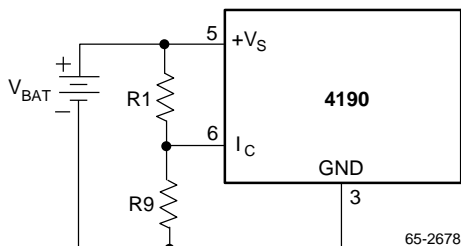

Figure 14. Automatic Shutdown

A resistor is placed from the IC pin to ground, creating a voltage divider. When the voltage at the IC pin is less than 1.2V, the RC4190 will begin to turn off. This scheme should only be used in limited temperature range applications since the “turn off” voltage at the IC pin has a temperature coefficient of $-4.0 \text{ mV}/^\circ\text{C}$. At 25°C , typically 250 nA is the minimum current required by the IC pin to sustain operation. A 5.0 μA voltage divider works well taking into account the sustaining current of 250 nA and a threshold voltage of 0.4V at turn off. As an example, if 3.0V is to be the turn off voltage, then $R9 = 1.1/4.75 \mu\text{A}$ and $R1 = (3.0 - 1.1) 5.0 \mu\text{A}$ or about 240 k Ω and 390 k Ω respectively. The tempo at the top of the divider will be -4.0 mV $(R1 + R9)/R9$ or $-10.5 \text{ mV}/^\circ\text{C}$, an acceptable number for many applications.

Another method of automatic shutdown without temperature limitations is the use of a zener diode in series with the IC pin and set resistor. When the battery voltage falls below $V_Z + 1.2\text{V}$ the circuit will start to shut down. With this connection and the low battery detector, the application can be designed to signal a display when the battery voltage has dropped to the first programmed level, then shut itself off as the battery reaches the zener threshold.

The set current can also be turned off by forcing the IC pin to 0.2V or less using an external transistor or mechanical switch. An example of this is shown in Figure 15.

In this circuit an external control voltage is used to determine the operating state of the RC4190. If the control voltage V_C is a logic 1 at the input of the 4025 (CMOS Triple NOR Gate), the voltage at the IC pin will be less than 0.5V forcing the 4190 off ($<0.1 \mu\text{A} I_{CC}$). Both the 2N3904 and 2N2907 will be off insuring long shelf for the battery since less than 1.0 μA is drawn by the circuit.

When V_C goes to a logic 0, 2.0 μA is forced into the IC pin through the 2.2 M Ω resistor and the NOR gate, and at the same time the 2N3904 and 2N2907 turn on, connecting the battery to the load.

As long as V_C remains low the circuit will regulate the output to 5.0V. This type of circuit is used to back up the main supply voltage when line interruptions occur, a particularly useful feature when using volatile memory systems.

9.0V Battery Life Extender

Figure 16 shows a common application: a circuit to extend the lifetime of a 9.0V battery. The regulator remains in its quiescent state (drawing only 215 μA) until the battery voltage decays below 7.5V, at which time it will start to switch and regulate the output at 7.0V until the battery falls below 2.2V.

If this circuit operates at its typical efficiency of 80%, with an output current of 10 mA, at 5.0V battery voltage, then the average input current will be $I_{IN} = (V_{OUT} \times I_L) \div (V_{BAT} \times \text{ef})$ or $(7.0\text{V} \times 10 \text{ mA}) \div (5.0\text{V} \times 0.8) = 17.5 \text{ mA}$.

Bootstrapped Operation (Step-Up)

In step-up applications, power to the RC4190 can be derived from the output voltage by connecting the +Vs pin and the top of R1 to the output voltage (Figure 17).

One requirement for this circuit is that the battery voltage must be greater than 3.0V when it is energized or else there will not be enough voltage at pin 5 to start up the IC. The big advantage of this circuit is the ability to operate down to a discharged battery voltage of 1.0V.

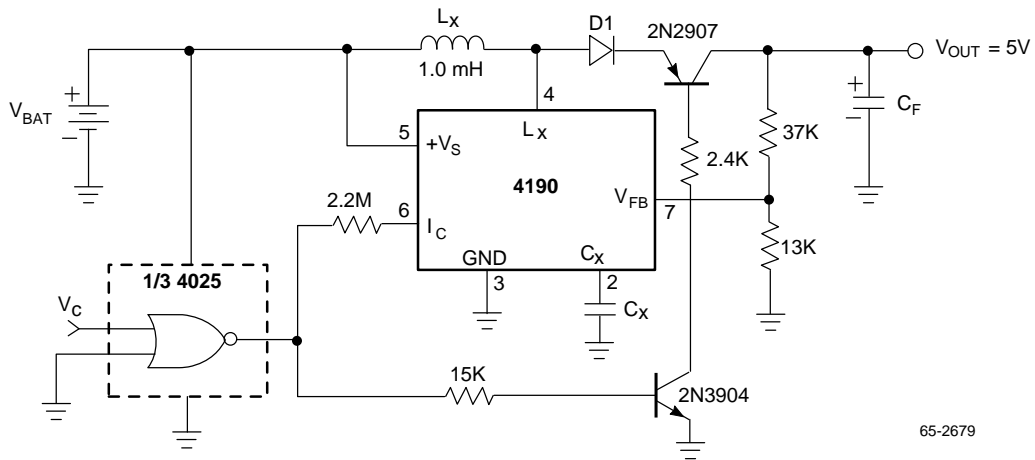

65-2679

Figure 15. Battery Back-Up Circuit

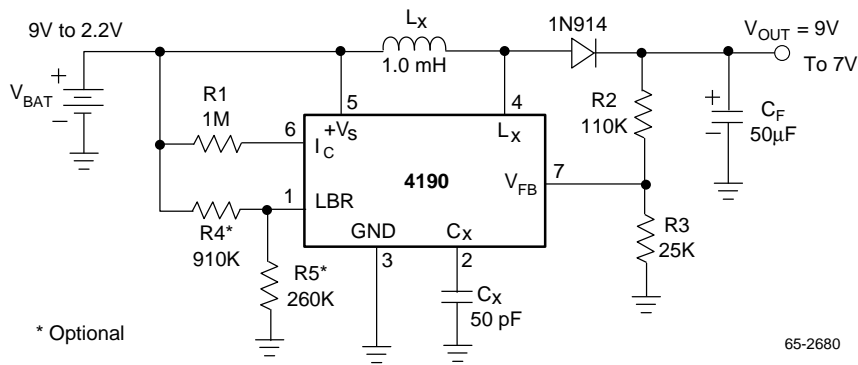

65-2680

Figure 16. 9.0V Battery Life Extender

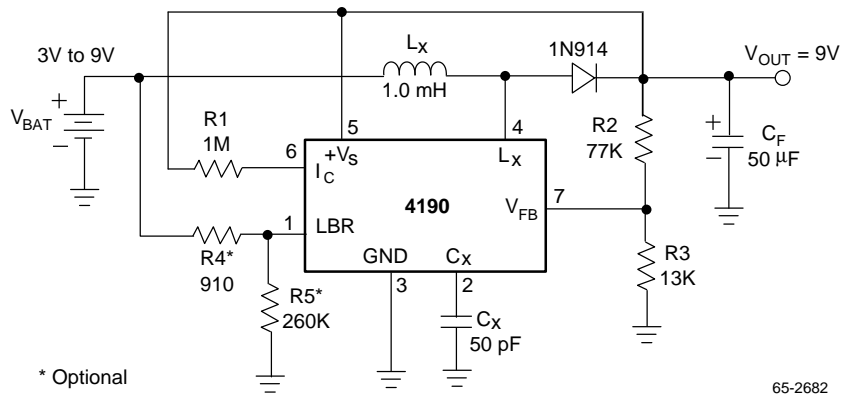

65-2682

Figure 17. Bootstrapped Operation (Step-Up)

Buck-Boost Circuit (Step-Up/Down)

A disadvantage of the standard step-up and step-down circuits is the limitation of the input voltage range; for a step-up circuit, the battery voltage must always be less than the programmed output voltage, and for a step-down circuit, the battery voltage must always be greater than the output voltage. The following circuit eliminates this disadvantage, allowing a battery voltage above the programmed output voltage to decay to well below the output voltage (see Figure 18).

The circuit operation is similar to the step-up circuit operation, except that both terminal of the inductor are connected to switch transistors. This switching method allows the inductor to be disconnected from the battery during the time the inductor is being discharged. A new discharge path is provided by D1, allowing the inductor to be referenced to ground and independent of the battery voltage. The efficiency of this circuit will be reduced to 55-60% by losses in the extra switch transistor and diode. Efficiency can be

improved by choosing transistors with low saturation voltages and by using power Schottky diodes such as Motorola's MBR030.

Step-Up Voltage Dependent Oscillator

The RC4190's ability to supply load current at low battery voltages depends on the inductor value and the oscillator frequency. Low values of inductance or a low oscillator frequency will cause a higher peak inductor current and therefore increase the load current capability. A large inductor current is not necessarily best, however, because the large amount of energy delivered with each cycle will cause a large voltage ripple at the output, especially at high input voltages. This trade-off between load current capability and output ripple can be improved with the circuit connection shown in Figure 19. This circuit uses the low battery detector to sense for a low battery voltage condition and will decrease the oscillator frequency after a pre-programmed threshold is reached.

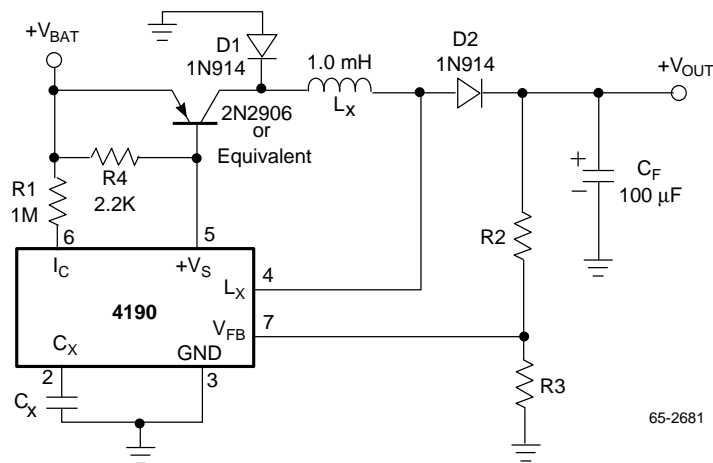

Figure 18. Buck Boost Circuit (Step-Up/Down)

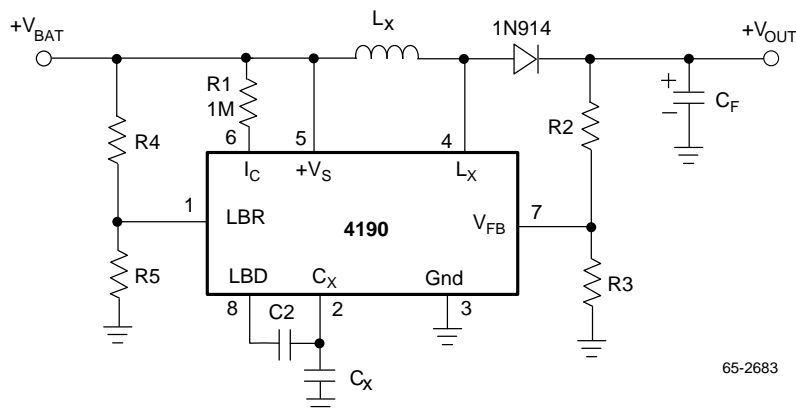

Figure 19. Step-Up Voltage Dependent Oscillator

The threshold is programmed exactly as the noram low battery detector connection:

$$V_{TH} = V_{REF} \left(\frac{R4}{R5} + 1 \right)$$

When the battery voltage reaches this threshold, the comparator will turn on the open collector transistor at pin 8, effectively putting C2 in parallel with CX. This added capacitance will reduce the oscillator frequency according to the following equation:

$$F_O = \frac{2.4 \times 10^{-6}}{C_X + C2}$$

Where C is in pF and FO is in Hz.

Component values for a typical application might be R2 = 330 kΩ, R5 = 150 kΩ, CX = 100 pF, and C2 = 100 pF. These values would set the threshold voltage at 4.1V and change the operating frequency from 48 kHz to 24 kHz. Note that this technique may be used for step-up, step-down, or inverting applications.

Step-Down Regulator With Protection

One disadvantage of the simple application circuits is their lack of short circuit protection, especially for the step-up circuit, which has a very low resistance path for current flow from the input to the output. A current limiting circuit which senses the output voltage and shuts down the 4190 if the output voltage drops too low can be built using the low battery detector circuitry. The low battery detector is connected to sense the output voltage and will shut off the oscillator by forcing pin 2 low if the output voltage drops. Figure 20

shows a schematic of a step-down regulator with this connection.

R2 and R3 set the output voltage, as in the circuit of Figure 2. Choose resistor values so R5 = R3 and R4 = R2, and make R8 25 to 35 times higher than R3. When the output is shorted, the open collector transistor at pin 8 will force pin 2 low and shut off the oscillator and therefore shut off the external switch transistor. The regulator will then remain in a low current off condition until power is removed and reapplied. C2 provides momentary current to ensure proper start-up. This scheme will not work with the simple step-up regulator, but will work with the boost-buck converter, providing short circuit protection in both step-up and step-down modes.

RC4190/RC4391 ± Power Supply

A positive and negative dual tracking power supply using a step-up RC4190 and an inverting RC4391 is shown in Figure 21. The inductor and capacitor values were chosen to achieve the highest practical output currents from a +12V battery, as it decays, while keeping the output voltage ripple under 100 mVp-p at ±15V output.

The circuit may be adapted to other voltages and currents, but note that the RC4190 is step-up, so VOUT must be greater than VBAT.

The output voltages may both be trimmed by adjusting a single resistor value (R3 or R4), because the reference for the negative output is derived from +VOUT. This connection also allows the output voltages to track each other with changes in temperature and line voltage.

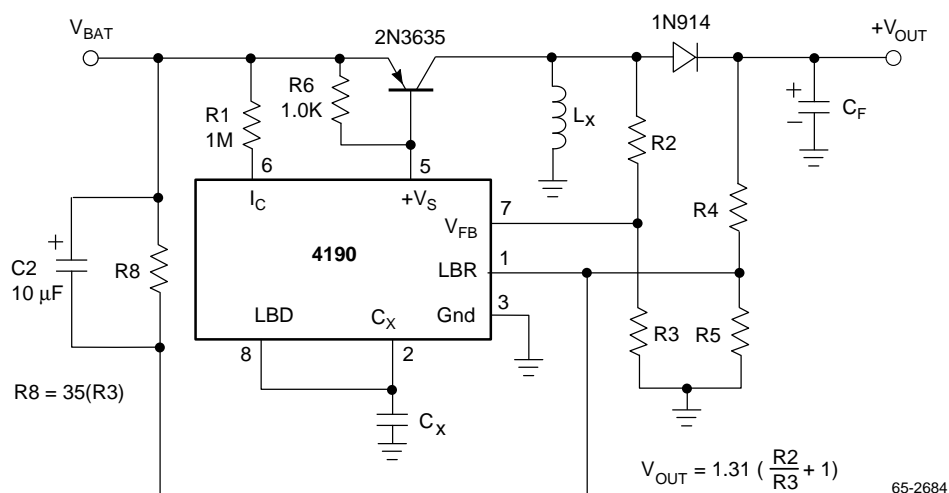

Figure 21. Step-Down Regulator with Protection

The timing capacitors are set up exactly as in the voltage dependent oscillator application of Figure 19. The values of R2, R5, C6, and C4 that are given were chosen to optimize for the +12V battery conditions, setting the threshold for oscillator frequency change at $V_{BAT} = +8.5V$.

As given, this power supply is capable of delivering +45 mA and -15 mA with regulation, until the battery decays below 5.0V.

For information on adjusting the RC4391 to meet a specific application refer to the Raytheon RC4391 data sheet.

Negative Step-Up Regulator

In the circuit of Figure 22, a bootstrap arrangement of supply and ground pins helps generate an output voltage more negative than the input voltage. On power-up, the output filter capacitor (C_F) will charge through D2 and L_X . When the voltage goes below -2.4V, the RC4190 begins switching and charging C_F . The output will regulate at a value equal to the reference voltage (1.31V) plus the zener voltage of D1. R_Z sets the value of zener current, stabilized at $1.31V/R_2$.

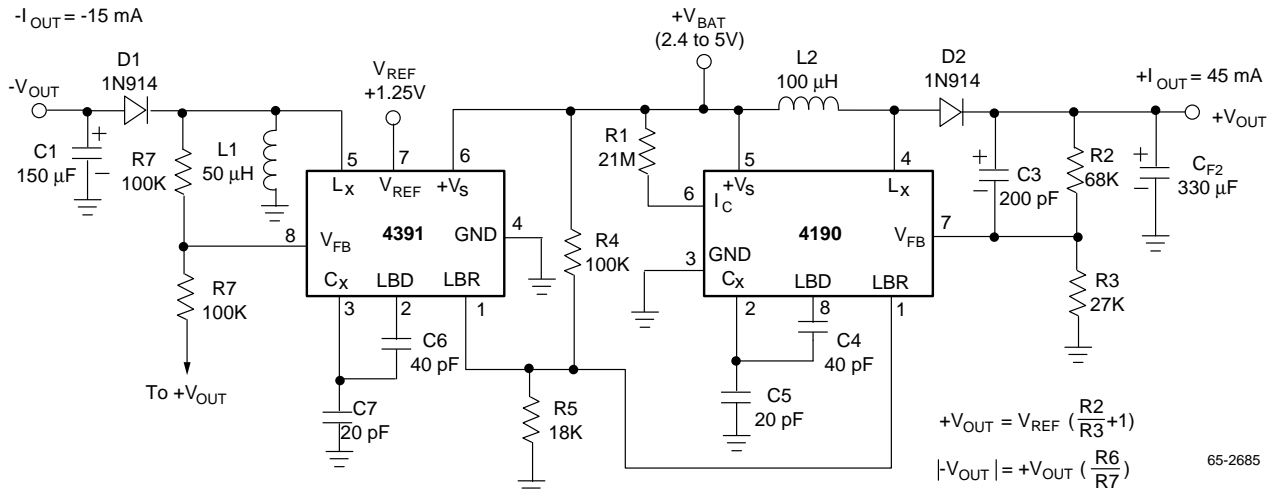

Figure 21. RC4190/RC4391 Power Supply ($\pm 15V$)

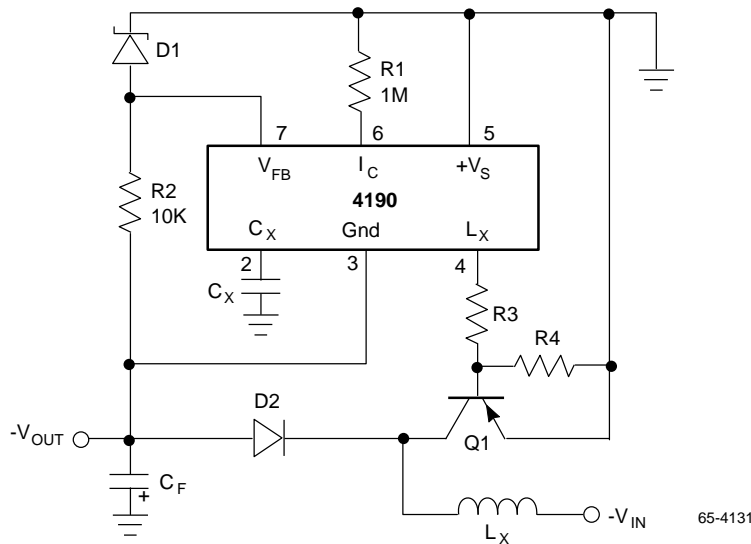
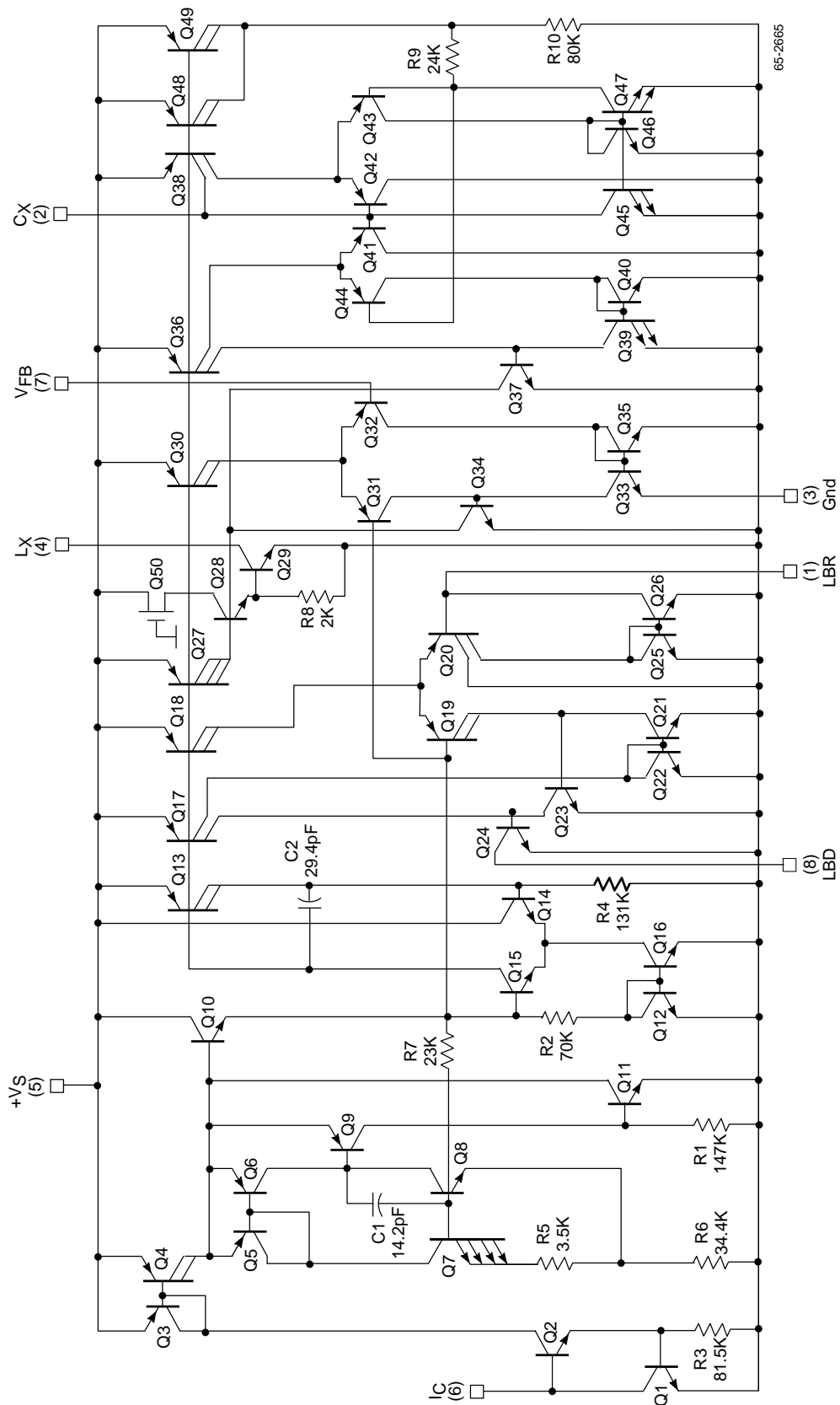
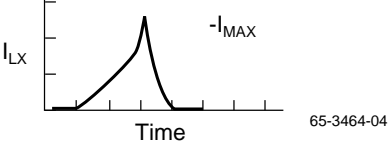
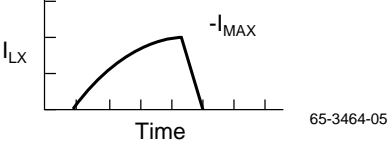
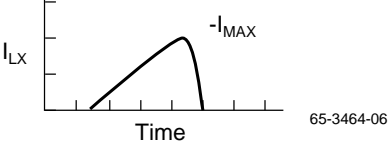

Figure 22. Negative Step-Up Regulator

Simplified Schematic Diagram



Troubleshooting Chart

Symptom	Possible Problem
Draws excessive supply current on start-up	Battery not "stiff" — inadequate supply bypass capacitor.
	Inductance value too low.
	Operating frequency (FO) too low.
Output voltage is low.	Inductance value too high for FO or core saturating.
Inductor "sings" with audible hum.	Not potted well or bolted loosely.
LX in appears noisy — scope will not synchronize.	Normal operating condition.
Inductor current shows nonlinear waveform. 	Inductor is saturating: 1. Core too small. 2. Core too hot. 3. Operating frequency too low.
Inductor current shows nonlinear waveform. 	Waveform has resistive component: 1. Wire size too small. 2. Power transistor lacks base drive. 3. Components not rated high enough. 4. Battery has high series resistance.
Inductor current is linear until high current is reached. 	External transistor lacks base drive or beta is too low.
Poor efficiency.	Core saturating.
	Diode or transistor: 1. Not fast enough. 2. Not rated for current level (high VCE SAT).
	High series resistance.
	Operating frequency too high.
Motorboating (erratic current pulses).	Loop stability problem — needs feedback capacitor from VOUT to VFB (pin 7), 100 to 1000 pF.

Background Information

During the past several years there have been various switching regulator ICs introduced by many manufacturers, all of which attended to the same market, namely controllers for use in power supplies delivering greater than 10W of DC power. Raytheon felt there was another area which could use a switching regulator to even more advance the area of battery powered equipment. Battery powered systems have problems peculiar unto themselves: changes in supply voltage, space considerations, battery life and usually cost. The RC4190 was designed with each of these in mind.

The RC4190 was partitioned to work in an eight pin package, making it smaller than other controllers which go into 14 and 16 pin packages.

Battery powered applications require the load as seen by the battery to be as small as possible to extend battery life. To this end, the quiescent current of the RC4190 is 15 to 100 times less than controllers designed for nonbattery applications. At the same time, the switch transistor can sink 200 mA at 0.4V, comparable to or better than higher powered controllers. As an example, the 4190 configured in the step-up mode can supply 5.0V at 40 mA output with an input of 3.0V.

Cost is usually a primary consideration in battery powered systems. The RC4190, guaranteed to work down to 2.2V, can save the designer and end user money as well because battery costs decrease as the number of cells needed goes down.

Soft Start

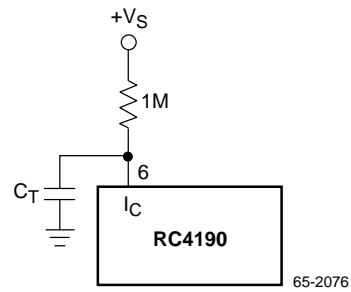

The delay introduced by the RC time constant at start-up allows the output filter capacitor to charge up, reducing the instantaneous supply current. A typical value for C is in the 0.1μF range.

Bootstrapped Low Voltage Start-Up

Figure 24 shows the bootstrapped application can be "kicked on" using an extra capacitor and triple pole double throw switch (3PDT). This connection allows the circuit to start up using a single Ni-Cad cell of 1.2V to 1.6V. When power is first applied the 1.2V battery does not provide enough voltage to meet the minimum 2.2V supply voltage requirement. The 22μF capacitor, when switched, temporarily doubles the battery voltage to bias up the RC4190.

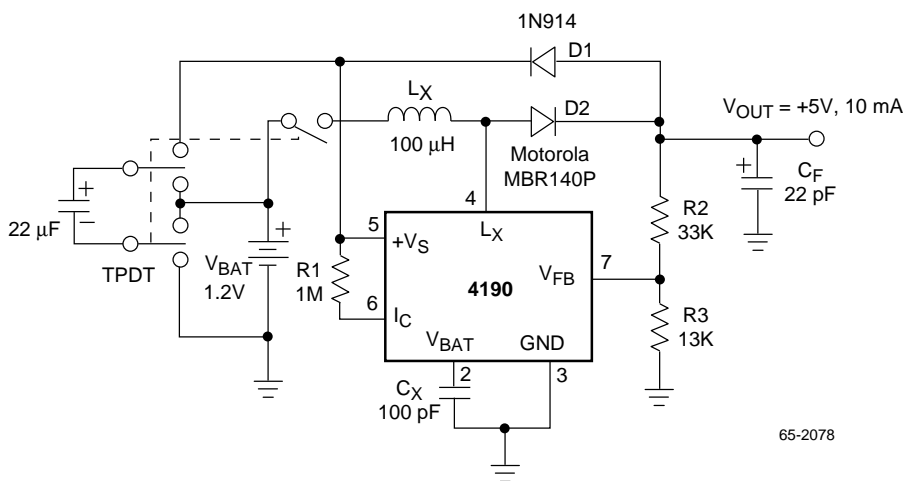

Figure 24. Bootstrapped Low Voltage Start-Up

When the switch is the down position, the capacitor charges up to the battery voltage. The, when the switch is changed to the up position, the capacitor is put in series connection with the battery, and the doubled voltage is applied directly to the positive power supply lead of the RC4190. This voltage is enough to bias the junctions internal to the RC4190 and gets it started. Then, when the stepped up output voltage reaches a high enough value, diode D1 is forward biased and the output voltage takes over supplying power to the RC4190. The circuit is shown with component values for +5V output, but the circuit can be set up for other voltages.

Electricity Versus Magnetism

Electrically the inductor must meet just one requirement, but that requirement can be hard to satisfy. The inductor must exhibit the correct value of inductance (L, in Henrys) as the inductor current rises to its highest operating value (IMAX). This requirement can be met most simply by choosing a very large core and winding it until it reaches the correct inductance value, but that brute force technique wastes size, weight and money. A more efficient design technique must be used.

Question: What happens if too small a core is used?

First, one must understand how the inductor's magnetic field works. The magnetic circuit in the inductor is very similar to a simple resistive electrical circuit (see Figure 20). There is a magnetizing force (H, in oersteds), a flow of magnetism, or flux density (B, in Gauss), and resistance to the flux, called permeability (U, in Gauss per oersted). H is equivalent to voltage in the electrical model, flux density is like current flow, and permeability is like resistance (except for two important differences discussed on the following page).

First Difference: Permeability, instead of being analogous to resistance, is actually more like conductance (1/R). As permeability increases, flux increases.

Second Difference: Resistance is a linear function. As voltage increases, current increases proportionally, and the resistance value stays the same. In a magnetic circuit the value of permeability varies as the applied magnetic force varies. This nonlinear characteristic is usually shown in graph form in ferrite core manufacturer's data sheets. See Figure 26.

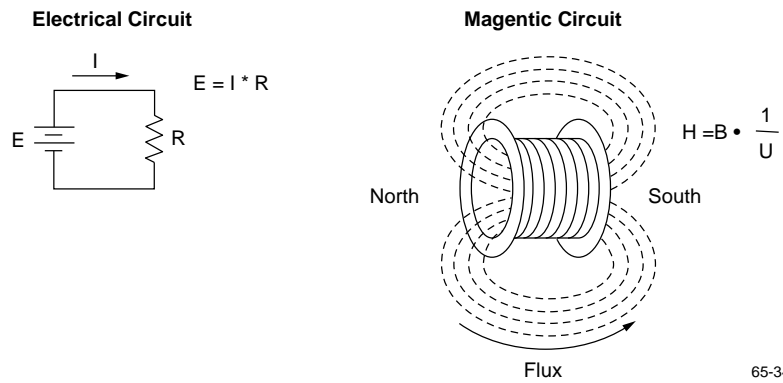

65-3464-07

Figure 25. Electricity Versus Magnetism

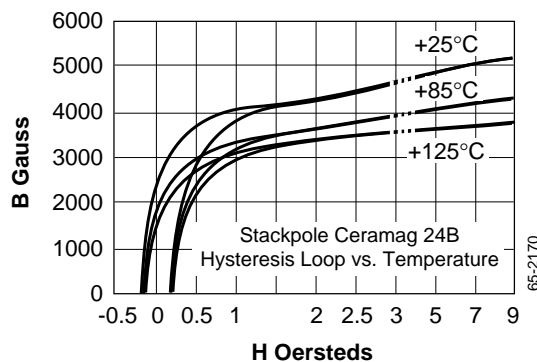

Figure 26. Typical Manufacturer's Curve Showing Saturation Effect

As the applied magnetizing force increases, at some point the permeability will start decreasing, and therefore the amount of magnetic flux will not increase any further, even as the magnetizing force increases. The physical reality is that, at the point where the permeability decreases, the magnetic field has realigned all of the magnetic domains in the core material. Once all of the domains have been aligned the core will then carry no more flux than just air; it becomes as if there were no core at all. This phenomenon is called saturation. Because the inductance value, L, is dependent on the amount of flux, core saturation will cause the value of L to decrease dramatically, in turn causing excessive and possibly destructive inductor current.

Pot Cores for RC4190

Pot core inductors are best suited for the RC4190 micropower switching regulator for several reasons:

1. **They are available in a wide range of sizes.** RC4190 applications are usually low power with relatively low peak currents (less than 500mA). A small inexpensive pot core can be chosen to meet the circuit requirements.
2. **Pot cores are easily mounted.** They can be bolted directly to the PC card adjacent to the regulator IC.
3. **Pot cores can be easily air-gapped.** The length of the gap is simply adjusted using different washer thicknesses. Cores are also available with predetermined air gaps.
4. **Electromagnetic interference (EMI) is kept to a minimum.** The completely enclosed design of pot core reduces stray electromagnetic radiation—an important consideration of the regulator circuit is built on a PC card with other circuitry.

Core Size

Question: Is core size selected according to load power?

Not quite. Core size is dependent on the amount of energy stored, not on load power. Raising the operating frequency allows smaller cores and windings. Reduction of the size of the magnetics is the main reason switching regulator design tends toward higher operating frequency. Designs with the RC4190 should use 75kHz as a maximum running frequency, because the turn off delay of the power transistor and stray capacitive coupling begin to interfere. Most applications are in the 10 to 50kHz range, for efficiency and EMI reasons.

The peak inductor current (I_{MAX}) must reach a high enough value to meet the load current drain. If the operating frequency is increased, and simultaneously the inductor value is decreased, then the core can be made smaller. For a given core size and winding, an increase in air gap spacing (an air gap is a break in the material in the magnetic path, like a section broken off a doughnut) will cause the inductance to decrease and I_{MAX} (the usable peak current before saturation) to increase.

The curves shown in Figure 26 are typical of the ferrite manufacturer's power HF material, such as Siemens N27 or Stackpole 24B, which are usually offered in standard millimeter sizes including the sizes shown.

Use of the Design Aid Graph (Figure 27)

1. From the application requirement, determine the inductor value (L) and the required peak current (I_{MAX}).
2. Observe the curves of the design aid graph and determine the smallest core that meets both the L and I requirements.

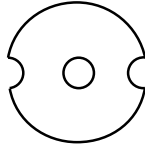
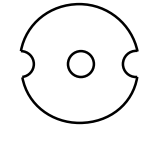
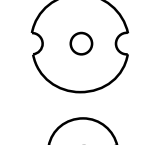
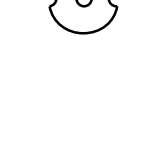
#1		22X 13 mm 24 Gauge 70 Turns DCΩ = 0.5Ω
#2		18X 11 mm 26 Gauge 70 Turns DCΩ = 0.7Ω
#3		14X 8 mm 28 Gauge 60 Turns DCΩ = 0.6Ω
#4		11X 7 mm 30 Gauge 50 Turns DCΩ = 1Ω

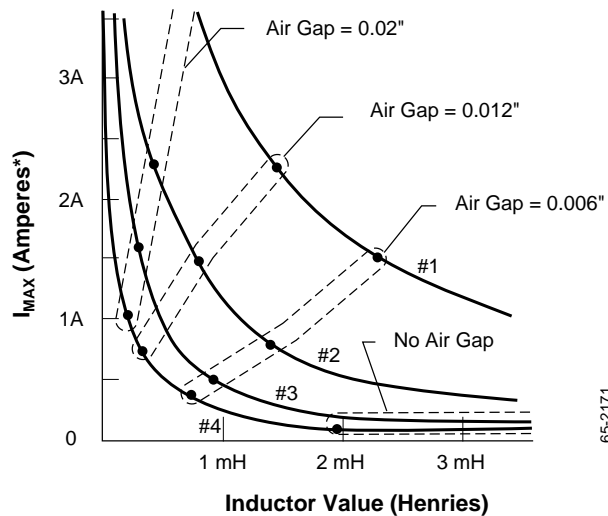

*Includes safety margin (25%) to ensure nonsaturation

Figure 27. Inductor Design Aid

- Note the approximate air gap at I_{MAX} for the selected core, and order the core with the gap. (If the gapping is done by the user, remember that a washer spacer results in an air gap of twice the washer thickness, because two gaps will be created, one at the center post and one at the rim, like taking two bites from a doughnut.)
- If the required inductance is equal to the indicated value on the graph, then wind the core with the number of turns shown in table of sizes. The turns given are the maximum number for that gauge of wire that can be easily wound in the cores winding area.
- If the required inductance is less than the value indicated on the graph, a simple calculation must be done to find the adjusted number of turns. Find A_L (inductance index) for a specific air gap.

$$\frac{L(\text{indicated})}{\text{Turns}^2} = A_L$$

in Henrys/turn²

Then divide the required inductance value by A_L to give the actual turns squared, and take the square root to find the actual turns needed.

$$\text{ActualTurns} = \frac{L(\text{required})}{A_L}$$

If the actual number of turns is significantly less than the number from the table then the wire size can be increased to use up the left-over winding area and reduce resistive losses.

- Wind and gap the core as per calculations, and measure the value with an inductance meter. Some adjustment of the number of turns may be necessary.

The saturation characteristics may be checked with the inductor wired into the switching regulator application circuit. To do so, build and power up the circuit. Then (recommend Tektronix P6042 or equivalent) around the inductor lead and monitor the current in the inductor. Draw the maximum load current from the application circuit so that the regulator is running at close to full duty cycle.

Compare the waveform you see to those pictured in Figure 28.

Check for saturation at the highest expected ambient temperature.

- After the operation in circuit has been checked, reassemble and pot the core using a potting compound recommended by the manufacturer.

If the core material differs greatly in magnetic characteristics from the standard power material shown in Figure 22, then the following general equation can be used to help in winding and gapping. This equation can be used for any core geometry, such as an E-E core.

$$L_x = \frac{(1.26) (N^2) (A_e) (10^8)}{g = (l_e) / (\mu_e)}$$

Where: N = number of turns

A_e = core area from data sheet (in cm²)

l_e = magnetic path length from data sheet (in cm)

μ_e = permeability of core from manufacturer's graph

g = center post air gap (in cm)

Manufacturers

Below is a list of several pot core manufacturers:

Ferroxcube Company
5083 Kings Highway
Saugerties, NY 12477

Indiana General Electronics
Keasley, NJ 08832

Siemens Company
186 Wood Avenue South
Iselin, NJ 08830

Stackpole Company
201 Stackpole Street
St. Mary, PA 15857

TDK Electronics
13-1-Chome
Nihonbashi, Chuo-ku, Tokyo

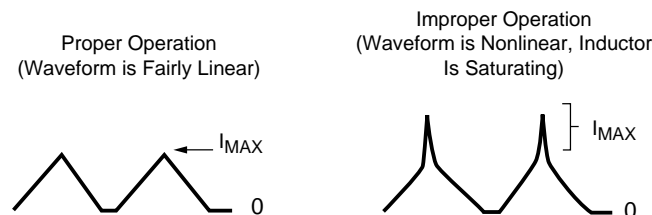

65-3464-08

Figure 28. Inductor Current Waveforms

Mechanical Dimensions

8-Lead Ceramic DIP Package

Symbol	Inches		Millimeters		Notes
	Min.	Max.	Min.	Max.	
A	—	.200	—	5.08	
b1	.014	.023	.36	.58	8
b2	.045	.065	1.14	1.65	2, 8
c1	.008	.015	.20	.38	8
D	—	.405	—	10.29	4
E	.220	.310	5.59	7.87	4
e	.100 BSC		2.54 BSC		5, 9
eA	.300 BSC		7.62 BSC		7
L	.125	.200	3.18	5.08	
Q	.015	.060	.38	1.52	3
s1	.005	—	.13	—	6
α	90°	105°	90°	105°	

Notes:

1. Index area: a notch or a pin one identification mark shall be located adjacent to pin one. The manufacturer's identification shall not be used as pin one identification mark.
2. The minimum limit for dimension "b2" may be .023 (.58mm) for leads number 1, 4, 5 and 8 only.
3. Dimension "Q" shall be measured from the seating plane to the base plane.
4. This dimension allows for off-center lid, meniscus and glass overrun.
5. The basic pin spacing is .100 (2.54mm) between centerlines. Each pin centerline shall be located within ± 0.010 (.25mm) of its exact longitudinal position relative to pins 1 and 8.
6. Applies to all four corners (leads number 1, 4, 5, and 8).
7. "eA" shall be measured at the center of the lead bends or at the centerline of the leads when " α " is 90°.
8. All leads – Increase maximum limit by .003 (.08mm) measured at the center of the flat, when lead finish applied.
9. Six spaces.

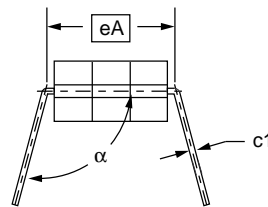
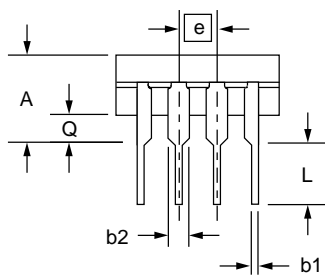
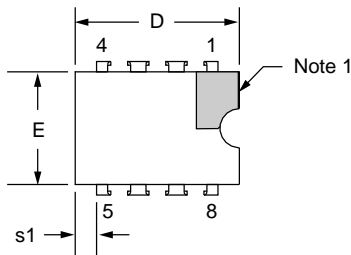

Mechanical Dimensions (continued)

8-Lead Plastic DIP Package

Symbol	Inches		Millimeters		Notes
	Min.	Max.	Min.	Max.	
A	—	.210	—	5.33	
A1	.015	—	.38	—	
A2	.115	.195	2.93	4.95	
B	.014	.022	.36	.56	
B1	.045	.070	1.14	1.78	
C	.008	.015	.20	.38	4
D	.348	.430	8.84	10.92	2
D1	.005	—	.13	—	
E	.300	.325	7.62	8.26	
E1	.240	.280	6.10	7.11	2
e	.100 BSC		2.54 BSC		
eB	—	.430	—	10.92	
L	.115	.160	2.92	4.06	
N	8°		8°		5

Notes:

1. Dimensioning and tolerancing per ANSI Y14.5M-1982.
2. "D" and "E1" do not include mold flashing. Mold flash or protrusions shall not exceed .010 inch (0.25mm).
3. Terminal numbers are for reference only.
4. "C" dimension does not include solder finish thickness.
5. Symbol "N" is the maximum number of terminals.

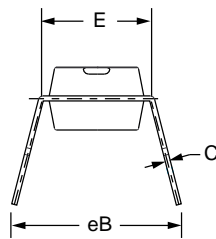
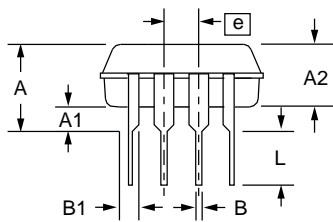
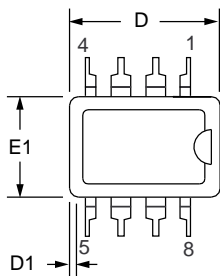

Mechanical Dimensions (continued)

8-Lead SOIC Package

Symbol	Inches		Millimeters		Notes
	Min.	Max.	Min.	Max.	
A	.053	.069	1.35	1.75	
A1	.004	.010	0.10	0.25	
B	.013	.020	0.33	0.51	
C	.008	.010	0.20	0.25	5
D	.189	.197	4.80	5.00	2
E	.150	.158	3.81	4.01	2
e	.050 BSC		1.27 BSC		
H	.228	.244	5.79	6.20	
h	.010	.020	0.25	0.50	
L	.016	.050	0.40	1.27	3
N	8		8		6
α	0°	8°	0°	8°	
ccc	—	.004	—	0.10	

Notes:

1. Dimensioning and tolerancing per ANSI Y14.5M-1982.
2. "D" and "E" do not include mold flash. Mold flash or protrusions shall not exceed .010 inch (0.25mm).
3. "L" is the length of terminal for soldering to a substrate.
4. Terminal numbers are shown for reference only.
5. "C" dimension does not include solder finish thickness.
6. Symbol "N" is the maximum number of terminals.

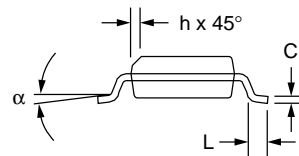
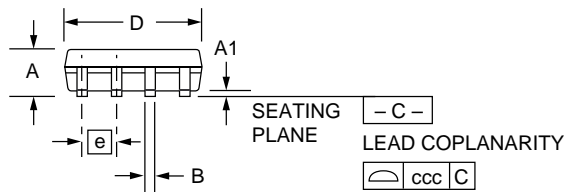
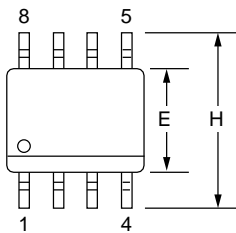

Ordering Information

Product Number	Temperature Range	Screening	Package
RC4190M	0° to 70°C	Commercial	8 Pin Narrow SOIC
RC4190N	0° to 70°C	Commercial	8 Pin Plastic DIP
RM4190D	-55°C to +125°C		8 Pin Ceramic DIP
RM4190D/883B	-55°C to +125°C	Military	8 Pin Ceramic DIP
RV4190N	-25°C to +85°C	Industrial	8 Pin Plastic DIP

Note:

1. /883B suffix denotes MIL-STD-883, Level B processing.

The information contained in this data sheet has been carefully compiled; however, it shall not by implication or otherwise become part of the terms and conditions of any subsequent sale. Raytheon's liability shall be determined solely by its standard terms and conditions of sale. No representation as to application or use or that the circuits are either licensed or free from patent infringement is intended or implied. Raytheon reserves the right to change the circuitry and any other data at any time without notice and assumes no liability for errors.

LIFE SUPPORT POLICY:

Raytheon's products are not designed for use in life support applications, wherein a failure or malfunction of the component can reasonably be expected to result in personal injury. The user of Raytheon components in life support applications assumes all risk of such use and indemnifies Raytheon Company against all damages.

Raytheon Electronics
Semiconductor Division
350 Ellis Street
Mountain View CA 94043
415 968 9211
FAX 415 966 7742